

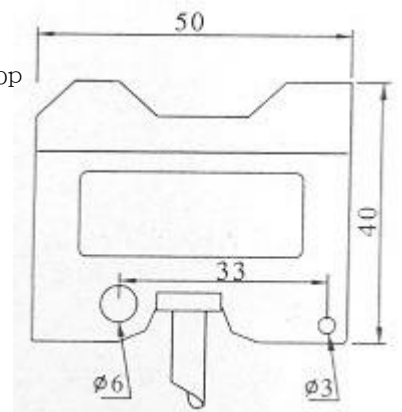

型號：三角光波-03N

Method of detection	Diffuse Reflective Type
Detecting Distance	3cm
Standard Object	Paper 10 × 10mm
Hysteresis	±10%
Degree Of Protection	IEC ,IP66
Indicator	RED LED
Protection Loop	Short Circuit & Reverse Protection Loop
Operating Temperature	- 25°C to + 55°C
Operating Humidity	35 to 85% RH
Ambient Operating Illumination	Incandescent light : 3000 Lux以下 Sun Light : 10000 Lux以下
Power Supply	10 - 30V DC
Output	PNP NO/NC NPN NO/NC
Current Consumption	<20mA
Load Current	200mA Max
Residual Output Voltage	1V Max
Response Frequency	1.5ms Max
Vibration Resistance	10 55Hz ; 1.5mm X,Y,Z Sustain 2 Hours
Shock Resistance	500m/S(約50g)X,Y,Z Sustain 3 Times
Cable Material	Length ; 2M Dia : 5mm 0.23m / 3 core wire
Housing Material	PBT PBT material
Wire Material	PVC PVC Oil resistance
Weight	95g

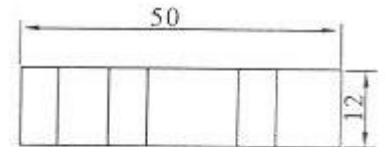

RE CHENG HSU AUTOMATIC INDUSTRIAL CO.,LTD

Address:NO.10.Lane 271,sec. 2 Pingdong Road.,
Pingjhen City,Taoyuan County 324,Taiwan(R.O.C)

TEL :886-3-460-1638

FAX :886-3-460-3820

E-mail :re.cheng@msa.hinet.net

Website:http://www.rc-drh.com.tw

南區營業所:台南縣永康市中正北路54號5樓之13

TEL:06-2434092

FAX:06-2434093